

**COLUMBINE
WATER AND SANITATION DISTRICT**

Petroleum, Oil, Grease and Sand (POGS) Policy

Adopted April 24, 2018

TABLE OF CONTENTS

TITLE	PAGE NUMBER
1.0 Purpose	3
2.0 Scope and Applicability	3
2.1 Scope	3
2.2 Applicability	3
2.2.1 Non-domestic users	3
2.2.2 Domestic users	3
3.0 Definitions and Acronyms	4
3.1 Definitions	4
3.2 Acronyms	4
4.0 Roles and Responsibilities	5
4.1 District	5
4.2 Division	5
4.3 Contractors	5
4.4 Users	5
5.0 Requirements	5
5.1 Required Notification by the User	5
5.2 Reviews and Approval	6
5.2.1 Plan Reviews	6
5.2.2 Other Reviews and Approvals	6
5.3 Sand/Oil Interceptor (SOI) Requirements	7
5.3.1 SOI Plumbing and Structural Requirements	7
5.3.2 SOI Sizing	8
5.3.3 SOI Location	10
5.3.4 SOI Closure	11
5.4 SOI Maintenance	11
5.5 Best Management Practices (BMPs)	12
5.6 Spill Prevention	13
5.7 Elevator Pits	13
5.8 Variances	13
6.0 Enforcement	13
7.0 References	14
Exhibit A Design Drawing for Sand/Oil Interceptor	15
Exhibit B POGS Plan Review Form	16
Exhibit C Sand/Oil Interceptor Sizing Criteria	18

1.0 Purpose

The purpose of this policy is to minimize the loading of petroleum oil, grease, and sand (POGS) entering Columbine Water and Sanitation District's (District) wastewater collection system and the Littleton/Englewood Wastewater Treatment Plant (L/E WWTP). POGS can contribute to pass-through of pollutants into the South Platte River and municipal sewage sludge and a volatile atmosphere within the District's collection system. Additionally, sand and minerals can cause sewer blockages in low flow lines resulting in a sanitary sewer overflow (SSO) and/or may cause damage to pumping equipment.

2.0 Scope and Applicability

2.1 Scope

This policy encompasses the entire service area of Columbine Water and Sanitation District including those areas that are located outside the District's legal boundaries but discharge wastewater into the District's wastewater collection system by agreement and/or permit.

2.2 Applicability

2.2.1 Non-domestic Users

This policy applies to any non-domestic user in the District's service area that has the potential to discharge wastes containing sand, grit, gravel, aggregate and/or petroleum by-products into the wastewater system. Examples of such facilities include but are not limited to: automobile or recreational vehicle service stations, fleet maintenance stations, mechanical repair shops, car or truck washes, machine shops, garden nurseries, stone cutters, warehouses, and parking garages. These users shall install and maintain a sand/oil interceptor (SOI) and/or implement best management practices (BMPs) as directed by the District. Users with an elevator pit must either install a SOI or implement one of the other options outlined in Section 5.7.

2.2.2 Domestic Users

This policy does not apply to domestic users. However, the best management practices (BMPs), set forth in this policy, are recommended for domestic users to assist in preventing pollutants from entering the collection system.

3.0 Definitions and Acronyms

3.1 Definitions

Best Management Practices (BMPs) - Schedules of activities, prohibitions or practices, maintenance procedures, and other management practices; it also includes treatment requirements, operating procedures, and practices to control plant site runoff, spillage or leaks, sludge or waste disposal, or drainage from raw materials storage.

Control Authority – The Columbine Water and Sanitation District, the Cities of Littleton and Englewood or their designee, including the Division.

District – The Columbine Water and Sanitation District.

Division – The Industrial Pretreatment Division of the Littleton/Englewood Wastewater Treatment Plant.

Domestic User – Any private residential user that discharges wastes derived from ordinary living processes excluding any commercial or industrial wastes.

Inactive SOI – An existing SOI that is no longer in use.

Non-domestic User – Any user that does not meet the criteria for categorization as a domestic user shall be considered a non-domestic user

Notice of Violation (NOV) – A written notice served upon a user who has violated or continues to violate any provision of this policy.

Publicly Owned Treatment Works (POTW) –Includes any devices or systems used in the collection, storage, treatment, recycling, and reclamation of sewage and any conveyances, which convey wastewater to a treatment plant.

Petroleum Oil, Grease, and Sand (POGS) – Any hydrocarbon or petroleum product including oils and greases, and/or sand, grit, gravel or any other aggregate.

Sand/Oil Interceptor (SOI) – A plumbing appurtenance or appliance that is installed in a sanitary drainage system to intercept POGS from a wastewater discharge and is identified by volume, baffle(s), not less than two (2) compartments, a total volume of not less than five-hundred (500) gallons, and gravity separation

User – Any person who contributes, causes, or permits the contribution of wastewater into the POTW

3.2 Acronyms

BMPs – Best Management Practices

L/E WWTP – Littleton/Englewood Wastewater Treatment Plant

POTW – public owned treatment works

NOV – notice of violation

POGS – petroleum oil, grease, and sand

SOI – sand/oil interceptor
SSO – sanitary sewer overflow

4.0 Roles and Responsibilities

4.1 District

The District is responsible for implementing this policy. Duties include but are not limited to reviewing building plans, inspecting applicable users for compliance, and enforcing policy requirements. The District may delegate these responsibilities to outside contractors who have been authorized to represent the District.

4.2 Division

The Division has oversight authority over the District’s adoption and implementation of this policy.

4.3 Contractors

Contractors may be delegated to perform the roles and responsibilities of the District.

4.4 Users

Users to whom this policy applies, as identified in Section 2.2, shall comply with all requirements listed in Section 5.0. Users shall permit inspections by the District with or without notice for the purpose of determining applicability and/or compliance with this policy.

5.0 Requirements

This section describes the requirements for all applicable users. Prior to purchasing a business or signing a lease for an existing retail or other type of space, it is recommended the user contact the District with questions about the POGS Policy and SOI requirements. This can help users avoid costly mistakes or oversights.

5.1 Required Notification by the User

The User shall inform the District prior to:

- Sale or transfer of ownership of the business; or
- Change in trade name under which the business is operated; or
- Change in nature of the services provided that affect the potential to discharge POGS pollutants; or
- Remodeling of the facility that may result in an increase in flow or pollutant loading or that otherwise requires the facility to submit plans or specifications for approval through a building or zoning department, or any other formal approval process of a city, county, or other jurisdiction

5.2 Reviews and Approval

The District shall review new construction and existing facilities or businesses undergoing any physical change, change in ownership, operations, or other changes that could alter the nature, properties, or volume of wastewater discharge, to ensure that the current POGS Sector Control Program policies are incorporated and implemented.

5.2.1 Plan Reviews

The user and/or owner of the property, business, industry, or an authorized representative of the user shall contact the District for the purpose of obtaining a plan review.

Plans are required to be submitted for approval prior to:

- Construction of any new building, structure, facility, or installation from which there is (or may be) a discharge of wastewater
- Expansion or remodeling of an existing building, structure, facility, or installation from which there is (or may be) a discharge of wastewater.

The review and/or approval of such plans and operating procedures shall in no way relieve the user from the responsibility of modifying such facilities as necessary to produce a wastewater discharge acceptable to the District and the Division.

Plans shall be reviewed to determine that wastewater plumbing requirements stated in this policy are met and may determine the need for a pretreatment device such as a sand/oil interceptor (SOI) or other treatment process equipment.

If the District determines that a SOI is required, the District will determine the minimum SOI capacity in accordance with Section 5.3.2. All plans submitted to the District must show the location of the SOI, clearly identify plumbing and plumbing fixtures that connect to the SOI, and include dimensions or surface areas of all areas that have the potential to drain to the SOI. Plans must identify the intended use for each area e.g. hand wash/detail area, service bays, chemical storage, parking area, and automated or hand spray vehicle wash bays. Plans must also include a SOI detail showing internal plumbing, dimensions, cleanouts, and vent piping.

Written approval from the District must be obtained prior to installation of the SOI. If plan approval has been obtained, said plans shall not be deviated from. If a situation warrants the change of an approved plan, an amended copy must be resubmitted to the District for approval. SOI installation and associated plumbing shall be inspected and approved by the District prior to backfilling.

5.2.2 Other Reviews and Approvals

Upon sale or transfer of ownership of a business, a change in trade name under which a business is operated, a change in the nature of the services provided that affects the discharge of wastewater, or as a result of inspection, the District shall evaluate or re-evaluate the facility or business to determine adherence to the requirements of this policy.

The District may determine that a SOI is required to be installed or that an existing SOI requires repairs, replacement, or closure in accordance with the requirements of Section 5.3.

The District may approve the use of an existing SOI if it can adequately protect the sanitary sewer system from POGS.

5.3 Sand/Oil Interceptor (SOI) Requirements

All users to whom this policy applies, as identified in Section 2.2 must comply with the requirements of the POGS policy which may include the requirement for installation and operation of a SOI.

5.3.1 SOI Plumbing and Structural Requirements

All drains from shop areas, storage areas, mop sinks, wash bays, vehicle storage areas, and/or other areas with the potential to discharge POGS shall be connected to a SOI. If an oil or chemical storage room is too small for all oil and chemicals to be kept in containment or away from any floor drain, no floor drain shall be placed in that room. Fixtures to be connected include, but are not limited to, floor drains, hand sinks, and wash areas located in areas where sand and petroleum-based liquid waste materials may enter the collection system. Drains from areas that may produce wastewater laden with animal or vegetable fats, oils, and grease shall not be routed to the SOI. SOI's shall not be connected to roof drains, downspouts, or otherwise exposed to stormwater runoff. Outdoor drains or wash bays connected to SOI's must be roofed and bermed in such a manner as to keep storm water out of the sanitary sewer collection system.

Each business establishment for which a SOI is required shall have a SOI serving only that establishment. Common or shared SOIs are not permitted. The District may grant a variance for a common or shared SOI if it is pre-existing. Common or shared SOIs may be re-evaluated for proper sizing and capacity as facilities change business operation, practices, owners, or tenants.

All SOIs and associated plumbing shall be installed by a licensed plumber or contractor. All SOIs must have two compartments separated by a baffle wall. The primary compartment shall have a volume equal to two-thirds of the total capacity, and the secondary compartment shall have a volume equal to one-third of the total capacity. Each compartment shall be accessible by a traffic rated manhole above the inlet and outlet piping with a minimum diameter of 24 inches. Manhole covers may not be locked, or otherwise fastened in place, such that access is restricted.

All plumbing shall be compatible with wastewater containing POGS, such as PVC. A sampling-T with a removable cap shall be placed at the outlet end of the SOI to allow sampling of effluent. The top of the sampling-T shall be no more than one foot below grade. In order to maximize retention time in the primary chamber, the bottom of the inlet piping shall extend down no less than 50% of the total water depth. The bottom of the outlet piping must extend down within 9 to 12 inches from the floor of the SOI. Flow from the primary to secondary compartment shall be through a baffle pass-through port or over the top of the baffle. The baffle wall pass-through port or top of the baffle shall be no more than 5 inches below water line. If a pass-through port is used, the cross sectional area shall be at least equivalent to the cross sectional area of the inlet piping into the SOI. Support brackets are required for inlet and outlet piping. Clean outs and venting shall be PVC pipes. SOIs shall have two (2) vent pipes, one to vent the body of the SOI

and one to connect to the external effluent piping. Vent pipes shall remain independent to a location above finished grade. Each vent pipe shall have an accessible clean out prior to joining into a common vent. Vents shall be independent of any other building venting system and shall be in accordance with local building codes. Refer to Exhibit A for a diagram of a SOI.

Car washes with individual wash bays or heavy equipment wash bays shall have a catch basin located directly below the drain of each bay. The catch basin(s) shall be connected to the SOI.

If the District has determined that no SOI is to be installed, the user shall connect all plumbing fixtures listed in Section 5.3.1 to a sanitary sewer line separate from the domestic sanitary sewer line. This separate sanitary sewer line shall have a cleanout located outside of the building to allow the District access for sampling. The separate sanitary sewer line is designed to allow representative compliance sampling and future installation of a SOI should one be required. This line may be combined with the domestic sanitary sewer at a point after this cleanout.

5.3.2 SOI Sizing

The minimum capacity of a SOI is 500 gallons.

SOI's shall be adequately sized to protect the POTW and the collection system. When completed, the sizing calculation will provide a minimum holding capacity of the SOI in gallons. SOI sizing is based on surface area and intended use of areas that have the potential to produce POGS. Some facilities may have multiple distinct areas with like or unlike uses, for example, an auto service shop may have repair, storage, and vehicle or equipment washing areas, a car washing facility may have automatic and hand held spray washing bays along with a product storage area.

Sand/Oil Interceptor (SOI) Sizing Table

<i>PART A: Service Areas, Warehouse/Storage Areas, and Parking Garages:</i>				
Area Description ⁽¹⁾	Square Footage ⁽²⁾	Required SOI Cubic Foot Holding Capacity ⁽³⁾	Conversion Factor 7.48 gallon per Cubic Foot ⁽⁴⁾	Required Gallons of SOI Holding Capacity Per Area ⁽⁵⁾
			7.48	
			7.48	
			7.48	
			7.48	
			7.48	
			7.48	
Total (Gallons) From Part A				
<i>PART B: Commercial Truck, Equipment, and Car Washes:</i>				
Wash Bay Description ⁽⁶⁾	# of Bays ⁽⁷⁾	Required SOI Capacity Per Bay ⁽⁸⁾	Required Gallons of SOI Holding Capacity ⁽⁹⁾	
Total (Gallons) From Part B				
Total Required SOI Capacity (Minimum in Gallons) ⁽¹⁰⁾				

Completing the Table:

Part A:

1. Area Description, e.g. parking garage level 1, west service area, inside vehicle storage area, detailing area. Areas listed shall only include areas with drains that will flow to the SOI.
2. Square footage for each area that will or has the potential to drain into the SOI through normal operating processes or cleaning operations. (Length in feet x width in feet). The entire area shall be used in this calculation unless there is a physical barrier such as a wall that provides complete isolation of a non-draining area.
3. Required SOI Cubic Foot Holding Capacity involves the conversion of each area square footage to cubic feet of SOI holding capacity and shall be calculated as follows:
 - a.) 6 cubic feet of SOI holding capacity for the first 100 square feet of area plus 1 cubic foot of SOI holding capacity for each additional 100 square feet of area.
 - b.) Areas deemed storage or warehouse that has floor drains shall use a calculation conversion of 1 cubic foot of SOI holding capacity per 500 square feet. Areas used for the storage of chemical products are not considered storage/warehouse and shall use part 3 (a) above
 - c.) Commercial parking garages shall use a calculation conversion of 1 cubic foot of SOI holding capacity per 1000 square feet of surface area. Do not include the top level of the parking garage if it is exposed to storm events. Runoff from this level shall be drained to the storm water system.
4. Conversion Factor, SOIs are typically sized by gallons of holding capacity (1 cubic foot of SOI holding capacity = 7.48 gallons)
5. Required Gallons of SOI Holding Capacity per Area = required SOI cubic foot holding capacity of the area x 7.48 gallons per cubic foot

Part B:

6. Wash Bay Description, either Self Service (hand held spray) or In-Bay Automatic.
7. Number of bays employed for each wash bay description
8. Required SOI Holding Capacity Per Bay: 180 gallon SOI holding capacity for each Self Service wash bay, 387 gallon SOI holding capacity for each In-Bay Automatic
9. Required Gallons of SOI Holding Capacity per wash bay type = number of bays multiplied by required capacity per bay,

Total:

10. Total required SOI holding capacity (total gallons from Part A plus total gallons from Part B)

In the event a building is to be constructed or remodeled but tenant use information is not known, use the sizing criteria stated in note 3 part (a) above.

Part A shall be used for calculating SOI sizing requirements for industrial uses such as auto service, parking structures, storage/warehouse or miscellaneous processes subject to the POGS Sector Control Program requirements for installing and operating a SOI. Areas used for hand washing and detailing shall use Part A (3)(a).

Part B shall be used for facilities deemed commercial truck, equipment, or car washes.

Parts A and B shall be completed for facilities that are deemed mixed use (washing or detailing bays along with areas identified in Part A).

If multiple SOIs are required, a separate Plan Review Form shall be used for each SOI.

An SOI sizing job aid has been prepared to assist in calculating SOI sizing requirements.

5.3.3 SOI Location

Each SOI shall be so installed and connected that it shall be at all times easily accessible for inspection, cleaning, pumping, and maintenance. Each SOI manhole cover shall be readily accessible and safely removable for servicing and maintaining the SOI in good working condition. The use of ladders, the removal of bulky equipment, or any other circumstances that impedes safe access in order to service or inspect SOIs shall constitute a violation of accessibility. SOIs are not permitted to be located in parking spaces or driveways with heavy traffic. The location of all SOIs shall be shown on the approved building plan.

5.3.4 SOI Closure

The District may determine that a SOI is no longer required for its intended purpose. This may occur when the wastewater flow through the interceptor is significantly lower or non-existent due to changes in operations or physical changes. A lack of flow through the SOI may result in potential health and safety hazards.

Inactive SOIs shall be closed by:

- Complete removal of SOI contents (petroleum oil, solids, water, etc.), - performed by a professional service company,
- Submittal of plans or a narrative to the Division detailing the proposed scope of work,
- Sealing of all floor drains and fixtures plumbed to the SOI (if capping of SOI inlet and outlet pipes is required), or the installation of a direct pipe connection from the inlet to the outlet,
- Filling of the empty SOI with an appropriate fill material such as sand or fine aggregate, and
- Securing the opening(s) to the interceptor (e.g. cement, weld, etc.), or removing manhole ring and cover and providing adequate surfacing material.

The District may request plans detailing the closure activity and written approval from the District may be required prior to beginning work. Inspections of closure activities may be required by the District prior to securing the opening of the SOI. The user may be required to notify the District prior to closure of the SOI to allow for inspection.

5.4 SOI Maintenance

SOIs shall be maintained, at the expense of the user, by regularly scheduled pumping to ensure proper operation necessary to efficiently intercept POGS from the user's wastewater and prevent a sanitary sewer overflow and prevent the discharge of said materials into the District's wastewater collection system.

A SOI shall be serviced at a minimum of every 90 days for truck washes, heavy equipment washes, and commercial car washes. A SOI shall be serviced at a minimum once per year for all other users. The SOI may be required to be serviced more frequently as needed to ensure the total accumulation of solids, debris, and oil does not exceed 25% of the total capacity of the SOI. The District may allow a less frequent pumping schedule if the user can demonstrate the SOI does not need to be pumped per policy requirements. Users seeking a modified pumping schedule shall complete an application including information that demonstrates that a less frequent schedule is adequate. Applications will be reviewed by the District. Written approval must be obtained by the District before any modified pumping schedule can be implemented. All users are required to structurally maintain all components of their SOI as per the design requirements in Section 5.3.1 of this document.

Maintenance of SOI shall be done in a workman-like manner only by a business or professional normally engaged in the servicing of such plumbing fixtures. Partial removal of contents is not allowed. Contents removed from SOIs shall be hauled off-site and disposed of properly. Under no circumstances shall the SOI's contents be reintroduced to the sanitary sewer system. The user must take reasonable steps to assure that all waste is properly disposed of at a facility in accordance with federal, state and local regulations (i.e. through a certification by the hauler included on the waste manifest or trip ticket for each load.) Users are responsible for the maintenance, servicing and proper waste disposal and cannot abrogate this responsibility to a contractor, pumping service or any other agent.

All records, receipts, and manifests of SOI maintenance, removal of SOI contents, and off-site hauling of POGS waste shall remain on-site and accessible for review by the District for a minimum of three (3) years. The District may require a user that falls under the provisions of this policy to submit copies of all records, receipts, and manifests of SOI maintenance, removal of SOI contents, and off-site hauling of POGS waste.

In the event a SOI is not properly maintained by the user, the District may authorize such maintenance work to be performed on behalf of the user. The costs of such maintenance shall be billed directly to the user and shall become part of the charges due and owing to the District and shall constitute a lien against the property until paid in full. Failure to pay said charges may also result in discontinuance of service.

Biological treatment or enzyme treatment shall not be a substitute for the servicing of the SOI at the frequency determined by the District. Use of enzymes to bypass the SOI is prohibited.

5.5 Best Management Practices (BMPs)

The purpose of BMPs is to minimize the discharge of POGS into the sanitary sewer system. The following BMPs shall be implemented by non-domestic users to whom this policy applies:

- **Installation of mesh screens.** Facilities with the potential to discharge debris greater than 1/2" in any dimension shall install a mesh screen or similar device to prevent such debris from entering the SOI.
- **Storage and disposal of wastes and raw materials.** SOIs shall not be used as a means for disposal of spent or spilled chemicals, automotive or other commercial/industrial fluids, sludge, or other substances. All spent or spilled chemicals, automotive or other commercial/industrial fluids, sludge, oils, or other substances shall be collected and stored properly in appropriate containers. Such containers shall be maintained to ensure that they do not leak. Raw materials and wastes shall be stored per section 5.3 of this policy. Any wastes shall be disposed of in accordance with all federal, state, and local laws.
- **Employee training.** Employee training shall be provided as part of the normal orientation process and annually thereafter including, at a minimum, the following subjects:
 - How to sweep floors prior to floor wash down to ensure there is no excessive oil or sand entering the sanitary sewer,
 - The location, use, and disposal of absorption products to clean any spills (washing spills into drains is prohibited.), and
 - How to properly dispose of oils and other wastes into designated containers without spilling.
 - Proper storage of batteries.

Training shall be documented and employee signatures retained indicating each employee's attendance and understanding of the practices reviewed. Training records shall be made available for review at any reasonable time by the District.

- **Signage.** Signs shall be posted above all sinks and similar devices prohibiting the discharge of oil and other chemical waste down the drains.

5.6 Spill Prevention

All users are required to have measures in place to control unwanted discharge to the sanitary sewer. Chemicals, petroleum-based liquids, and other liquid products must be stored away from drains, away from traffic areas or within containment to reduce the potential for spills to reach the sanitary sewer or environment.

5.7 Elevator Pits

This section is applicable to new building construction or remodeling projects in which an elevator is to be installed.

- If the elevator shaft is required to have a floor drain or sump pit with sump pump the associated plumbing shall not be directly connected to the sanitary sewer.
- If a SOI is present or is required to be installed per Section 5.2, wastewater from the floor drain or elevator pit shall be plumbed through the SOI. A SOI shall not be installed for the sole purpose of draining the elevator pit, because not enough wastewater will pass through the SOI to allow it to function as designed. Elevator pits shall not be plumbed to a gravity grease interceptor.
- If a SOI is not present or required based on other infrastructure, the designer has the choice to drain the elevator pit through an oil separator or an oil sensing device with alarm shall be connected to a control device that will energize a valve to halt the wastewater flow. The designer may also drain the elevator pit to a holding reservoir or tank for off-site disposal by an approved waste hauler.

5.8 Variances

A variance to the requirements of this policy for existing users may be granted by the District for good cause. The user has the burden of proof of demonstrating through data and other information why a variance should be granted. In no case shall a variance result in a violation of any requirement or effluent limit specified in City of Littleton Municipal Code. The granting of any variance shall be at the discretion of the District and requires the approval of the Division.

If a variance is granted, the user shall institute BMPs and other mitigation measures, as determined by the District and Division.

6.0 Enforcement

The District has the authority to enforce the requirements specified herein. Upon inspection of a user's SOI and/or BMPs, the user will be given a copy of the inspection form. The inspection form will contain the inspection results and will indicate the deadline for any corrections if necessary.

Deadlines for violations are as follows:

{COL 00049124.1}

- Chemical storage/secondary containment issues must be resolved within 15 calendar days;
- SOI repairs must be completed within 15 calendar days;
- SOI pumping must be completed within five calendar days;
- Spills or leaks shall be cleaned-up within 24 hours;
- Missing or damaged floor drain covers or grates and screens must be replaced or repaired within 15 calendar days;
- Missing signage must be immediately replaced; and
- Violations involving improper employee BMP adherence shall require retraining of the employee and documentation of such training to be post marked, hand delivered, email, or faxed to the District within five calendar days.

If a user fails to make the corrections within the allotted timeframe a fine may be levied as an initial enforcement action. If noncompliance continues after a fine has been levied, the enforcement authority will escalate enforcement actions that could include both civil and criminal actions and discontinuance of service.

7.0 References

Englewood Municipal Code: Title 12, Chapter 2, Section 5

Littleton Municipal Code: Title 7, Chapter 5, Section 25

EXHIBIT A

HIGH RATE - DUAL COMPARTMENT

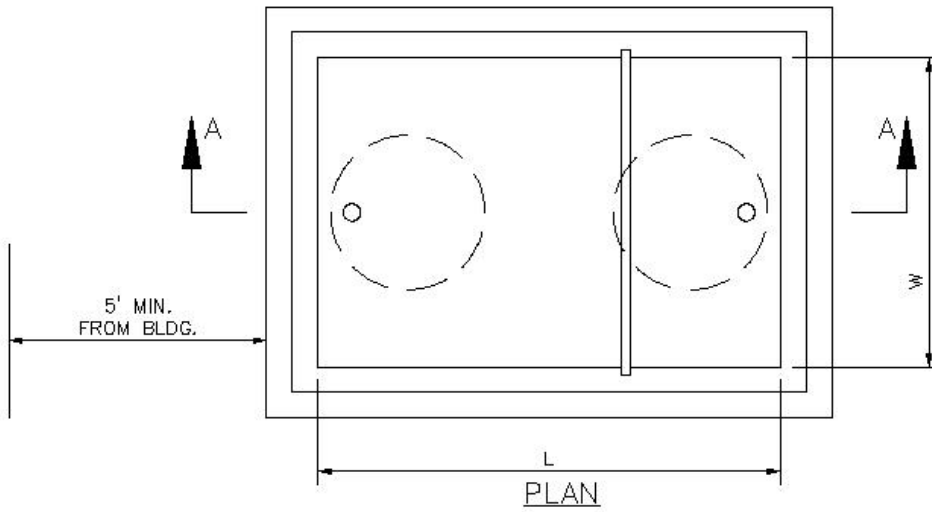

VENT "A" MAY RISE A MINIMUM OF 42" ABOVE FIXTURE FLOOD LINE AND MAY COMBINE WITH VENT "B" ABOVE THE 42" LINE TO FORM A SINGLE VENT THROUGH THE ROOF.

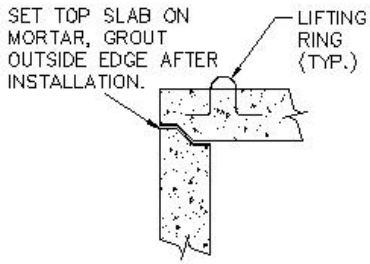
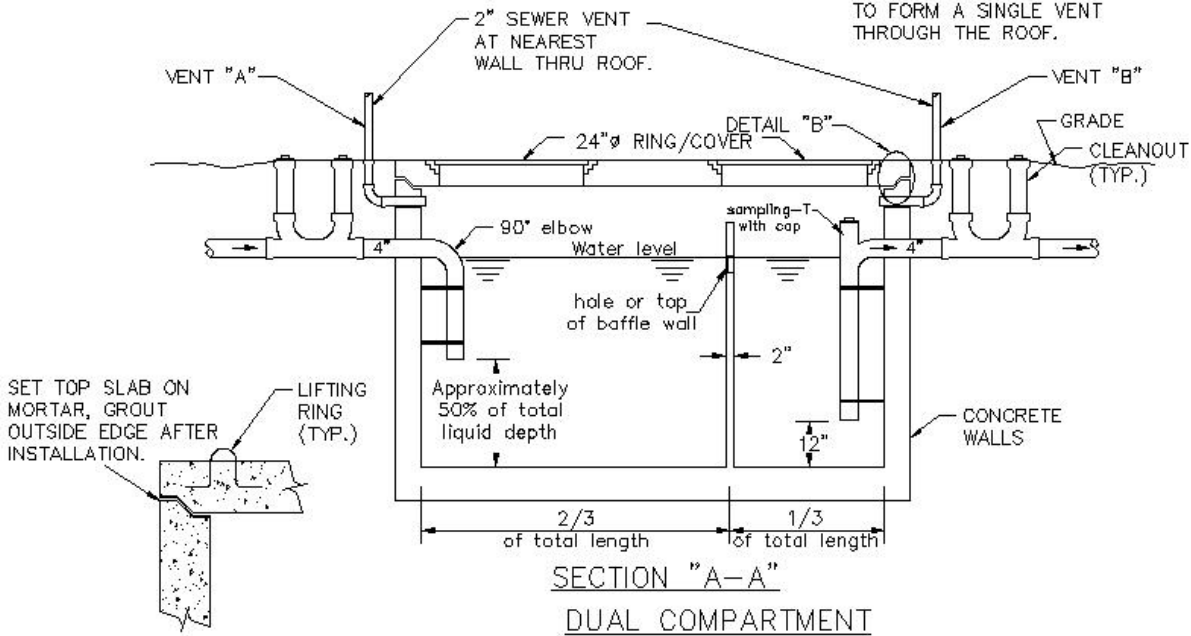

DETAIL B

EXHIBIT B

Columbine Water and Sanitation District POGS Plan Review Form

Facility Name: _____ Date: _____
 Address: _____
 Contact: _____ Phone: _____

Sand/Oil Interceptor (SOI) Sizing Table

<i>PART A: Service Areas, Warehouse/Storage Areas, and Parking Garages:</i>				
Area Description ⁽¹⁾	Square Footage ⁽²⁾	Required SOI Cubic Foot Holding Capacity ⁽³⁾	Conversion Factor 7.48 gallon per Cubic Foot ⁽⁴⁾	Required Gallons of SOI Holding Capacity Per Area ⁽⁵⁾
			7.48	
			7.48	
			7.48	
			7.48	
			7.48	
			7.48	
Total (Gallons) From Part A				
<i>PART B: Commercial Truck, Equipment, and Car Washes:</i>				
Wash Bay Description ⁽⁶⁾	# of Bays ⁽⁷⁾	Required SOI Capacity Per Bay ⁽⁸⁾	Required Gallons of SOI Holding Capacity ⁽⁹⁾	
Total (Gallons) From Part B				
Total Required SOI Capacity (Minimum in Gallons) ⁽¹⁰⁾				

1. Area Description, e.g. parking garage level 1, west service area, inside vehicle storage area, detailing area.
2. Square footage for each area (Length in feet x width in feet).
3. Required SOI Cubic Foot Holding Capacity shall be calculated as follows:
 - a) 6 cubic feet of SOI holding capacity for the first 100 square feet of area plus 1 cubic foot of SOI holding capacity for each additional 100 square feet of area.
 - b) Storage or warehouse with floor drains shall use a calculation conversion of 1 cubic foot of SOI holding capacity per 500 square feet.
 - c) Commercial parking garages: 1 cubic foot of SOI holding capacity per 1000 square feet of surface area. Do not include the top level of the parking garage if it is exposed to storm events.
4. Conversion Factor, (1 cubic foot of SOI holding capacity = 7.48 gallons)
5. Required Gallons of SOI Holding Capacity per Area = required SOI cubic foot holding capacity of the area x 7.48 gallons per cubic foot
6. Wash Bay Description, either Self Service (hand held spray) or In-Bay Automatic.
7. Number of bays employed for each wash bay description
8. Required SOI Holding Capacity Per Bay: 180 gallon SOI holding capacity for each Self Service wash bay, 387 gallon SOI holding capacity for each In-Bay Automatic
9. Required Gallons of SOI Holding Capacity per wash bay type = number of bays multiplied by reqd. capacity per bay,
10. Total required SOI holding capacity (total gallons from Part A plus total gallons from Part B) **(500 gal. minimum)**

In the event a building is to be constructed or remodeled but tenant use information is not known, use the sizing criteria stated in note 3 part (a) above.

Additional Plan Review Information:

1. Are all floor drains, hand sinks, and other plumbing fixtures in the wash, shop, and/or storage area connected to the SOI?

Do the restrooms bypass the SOI? _____

SOI location? _____

Has a SOI detail been included and does the detail meet all plumbing requirements? _____

Approved by: _____ Date: _____

EXHIBIT C

Columbine Water and Sanitation District Sand/Oil Interceptor Sizing Criteria

To be used in conjunction with the POGS Plan Review Form

Sand/Oil Interceptor (SOI) Sizing Table

(Use Notes 1 through 10 listed below to complete)

<i>PART A: Service Areas, Warehouse/Storage Areas, and Parking Garages:</i>				
Area Description ⁽¹⁾	Square Footage ⁽²⁾	Required SOI Cubic Foot Holding Capacity ⁽³⁾	Conversion Factor 7.48 gallon per Cubic Foot ⁽⁴⁾	Required Gallons of SOI Holding Capacity Per Area ⁽⁵⁾
			7.48	
			7.48	
			7.48	
			7.48	
			7.48	
			7.48	
Total (Gallons) From Part A				
<i>PART B: Commercial Truck, Equipment, and Car Washes:</i>				
Wash Bay Description ⁽⁶⁾	# of Bays ⁽⁷⁾	Required SOI Capacity Per Bay ⁽⁸⁾	Required Gallons of SOI Holding Capacity ⁽⁹⁾	
Total (Gallons) From Part B				
Total Required SOI Capacity (Minimum in Gallons) ⁽¹⁰⁾				

Completing the Table Notes:

Part A:

11. Area Description, e.g. parking garage level 1, west service area, inside vehicle storage area, detailing area. Areas listed shall only include areas with drains that will flow to the SOI.
12. Square footage for each area that will or has the potential to drain into the SOI through normal operating processes or cleaning operations. (Length in feet x width in feet). The entire area shall be used in this calculation unless there is a physical barrier such as a wall that provides complete isolation of a non-draining area.
13. Required SOI Cubic Foot Holding Capacity involves the conversion of each area square footage to cubic feet of SOI holding capacity and shall be calculated as follows:
 - d.) 6 cubic feet of SOI holding capacity for the first 100 square feet of area plus 1 cubic foot of SOI holding capacity for each additional 100 square feet of area.
 - e.) Areas deemed storage or warehouse that has floor drains shall use a calculation conversion of 1 cubic foot of SOI holding capacity per 500 square feet. Areas used for the storage of chemical products are not considered storage/warehouse and shall use part 3 (a) above.

- f.) Commercial parking garages shall use a calculation conversion of 1 cubic foot of SOI holding capacity per 1000 square feet of surface area. Do not include the top level of the parking garage if it is exposed to storm events. Runoff from this level shall be drained to the storm water system.
- 14. Conversion Factor, SOIs are typically sized by gallons of holding capacity (1 cubic foot of SOI holding capacity = 7.48 gallons)
- 15. Required Gallons of SOI Holding Capacity per Area = required SOI cubic foot holding capacity of the area x 7.48 gallons per cubic foot

Part B:

- 16. Wash Bay Description, either Self Service (hand held spray) or In-Bay Automatic.
- 17. Number of bays employed for each wash bay description
- 18. Required SOI Holding Capacity Per Bay: 180 gallon SOI holding capacity for each Self Service wash bay, 387 gallon SOI holding capacity for each In-Bay Automatic
- 19. Required Gallons of SOI Holding Capacity per wash bay type = number of bays multiplied by required capacity per bay,

Total:

- 20. Total required SOI holding capacity (total gallons from Part A plus total gallons from Part B)

Minimum allowable SOI size is 500 gallon capacity.

Occasionally the plan reviewer will not know the intended use of a facility being built or remodeled. In this case the SOI size will be calculated using Part A, using the required cubic foot capacity conversion of 6 cubic feet for the first 100 square feet of area, plus 1 cubic foot for each additional 100 square feet of area as provided in note 3 part (a) above.

How to Complete the Table

The SOI Sizing Table has two sections, Part A and Part B. Multiple Plan Review Forms shall be used if more than one SOI is to be installed.

Part A is to be completed for all potential drainage areas (garage service areas, detailing wash bays, storage/warehouse areas, parking garages etc.)

Part B is to be used for washing bays (car wash bays or truck or equipment bays)

In some facilities, both parts will need to be completed. Examples would be a service garage that also has a wash bay, or a car wash that also has a storage room for cleaning products.

Part A: Service Areas, Detailing Wash Bays, Warehouse/Storage Areas, and Parking Garages:

Enter an Area Description, typically when performing a plan review there are distinct drainage or use areas within the facility. Examples would be; parking garage level 1, vehicle/equipment storage area, service drive through area, warehouse area, manufacturing area, or service bays. Sometimes there are multiple areas intended for the same use located throughout the facility, in this case a location description can be added such as “west service bay area” or “northeast storage area”. It is typically easier to calculate square footage using distinct area dimensions and the various uses of areas within a facility have different SOI capacity requirements.

Square Footage: Basic length x width (in feet). The square footage needs to be calculated for each Area Description.

Required Cubic Foot Capacity: The plan reviewer calculates (converts) the square footage for each area description to cubic feet of SOI holding capacity based on area use using the criteria listed in note 3 below the table.

e.g. a service area encompasses 10,000 square feet. Using note 3 (a), the first 100 square feet requires 6 cubic feet capacity, the remaining 9,900 square feet requires 1 cubic feet capacity for each 100 square feet. Total SOI holding capacity for this area description would be 6 cubic feet + [(9,900 / 100) x 1 cubic feet] = 6 cubic feet + 99 cubic feet = 105 cubic feet.

If the intended use of the same 10,000 square foot area was storage/warehouse the required cubic foot SOI holding capacity would be [(10,000 / 500) x 1 cubic feet] = 20 cubic feet.

7.48 gallon per cubic foot: This is a constant, each cubic foot holding capacity previously calculated converts to 7.48 gallons of holding capacity in the SOI. Typically SOIs are specified to the manufacturer in gallons of holding capacity, such as 1000 gallon SOI.

Gallons Per Area: Calculated required SOI holding capacity for each area description.

Total (Gallons) From Part A: Summation of the individual “Gallons Per Area”

Part B: Commercial Truck, Equipment, and Car Washes:

Wash Bay Description: Self Service (hand held washing wand) or In-Bay Automatic (vehicle or equipment is driven through or conveyed through the wash bay as a machine performs the wash).

of Bays: Number of individual wash bays for each type of wash bay description.

Required Capacity Per Wash Bay: 180 gallons for self-service wash bays or 387 gallons for In-Bay Automatic wash bays.

Gallons: Number of bays (per description x required capacity per bay), e.g. 4 self-service wash bays x 180 gallons = 720 gallon SOI holding capacity

Total (Gallons) From Part B: Summation of the individual “Gallons” per wash bay description.

Total Required SOI Capacity (Minimum in Gallons): Sum of Part A plus Part B. This is the absolute minimum SOI capacity allowed at the facility. Some facilities may choose to specify a larger SOI.

Examples of Sizing Calculations Using The Table

Example 1

Automotive shop

Service area with trench drains = 8000 sq. ft.

Storage/warehouse area for parts and tire storage area with floor drain = 4000 sq. ft.

<i>PART A: Service Areas, Warehouse/Storage Areas, and Parking Garages:</i>				
Area Description ⁽¹⁾	Square Footage ⁽²⁾	Required SOI Cubic Foot Holding Capacity ⁽³⁾	Conversion Factor 7.48 gallon per Cubic Foot ⁽⁴⁾	Required Gallons of SOI Holding Capacity Per Area ⁽⁵⁾
Service Area	8000	85	7.48	635.8
Storage/Warehouse	4000	8	7.48	59.8
			7.48	
			7.48	
			7.48	
			7.48	
Total (Gallons) From Part A				695.6
<i>PART B: Commercial Truck, Equipment, and Car Washes:</i>				
Wash Bay Description ⁽⁶⁾	# of Bays ⁽⁷⁾	Required SOI Capacity Per Bay ⁽⁸⁾	Required Gallons of SOI Holding Capacity ⁽⁹⁾	
None			0	
Total (Gallons) From Part B				0
Total Required SOI Capacity (Minimum in Gallons) ⁽¹⁰⁾				695.6

Example 2

Commercial Parking Garage

1st level = 20,000 sq. ft.

2nd level = 20,000 sq. ft.

Top level uncovered (run-off from this level must be drained to the storm water system)

<i>PART A: Service Areas, Warehouse/Storage Areas, and Parking Garages:</i>				
Area Description ⁽¹⁾	Square Footage ⁽²⁾	Required SOI Cubic Foot Holding Capacity ⁽³⁾	Conversion Factor 7.48 gallon per Cubic Foot ⁽⁴⁾	Required Gallons of SOI Holding Capacity Per Area ⁽⁵⁾
1st Level	20,000	20	7.48	149.6
2nd Level	20,000	20	7.48	149.6
			7.48	
			7.48	
			7.48	
Total (Gallons) From Part A				299.2
<i>PART B: Commercial Truck, Equipment, and Car Washes:</i>				
Wash Bay Description ⁽⁶⁾	# of Bays ⁽⁷⁾	Required SOI Capacity Per Bay ⁽⁸⁾		Required Gallons of SOI Holding Capacity ⁽⁹⁾
None				0
Total (Gallons) From Part B				0
Total Required SOI Capacity (Minimum in Gallons) ⁽¹⁰⁾				299.2

- **Will require the minimum 500 gallon capacity SOI**

Example 3

Car Wash

Mechanical room with floor drains trench drains = 480 sq. ft.

Chemical storage room with floor drains = 280 sq. ft.

Six self-service vehicle wash bays

Two Automated vehicle wash bays

Commercial Car Wash With Additional Storage Areas

<i>PART A: Service Areas, Warehouse/Storage Areas, and Parking Garages:</i>				
Area Description ⁽¹⁾	Square Footage ⁽²⁾	Required SOI Cubic Foot Holding Capacity ⁽³⁾	Conversion Factor 7.48 gallon per Cubic Foot ⁽⁴⁾	Required Gallons of SOI Holding Capacity Per Area ⁽⁵⁾
Mechanical Room	480	9.8	7.48	73.3
Chemical Storage Room	280	7.8	7.48	58.3
			7.48	
			7.48	
			7.48	
			7.48	
Total (Gallons) From Part A				131.6
<i>PART B: Commercial Truck, Equipment, and Car Washes:</i>				
Wash Bay Description ⁽⁶⁾	# of Bays ⁽⁷⁾	Required SOI Capacity Per Bay ⁽⁸⁾	Required Gallons of SOI Holding Capacity ⁽⁹⁾	
Self Service Wash Bays	6	180	1080	
Automatic Wash Bays	2	387	774	
Total (Gallons) From Part B				1854
Total Required SOI Capacity (Minimum in Gallons) ⁽¹⁰⁾				1985